



Green Flash

High performance computing for real-time science

Real-time Simulator

Mid-term Review, 1 Feb 2017

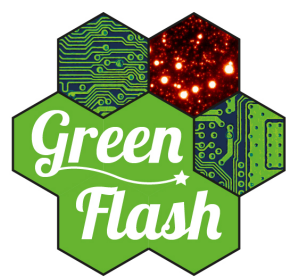

The logo for 'Green Flash' features a green hexagonal shape with a circuit board pattern and a red starburst pattern. The text 'Green Flash' is written in a white, stylized font across the green background.

Outline

- Motivation
- Requirements Review
- Concept Overview



MOTIVATION

MTR - 1-Feb-2017



Laboratoire d'Études Spatiales et d'Instrumentation en Astrophysique



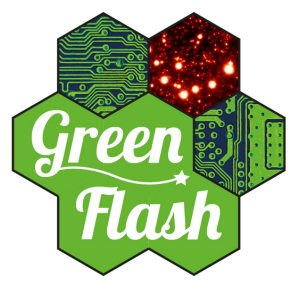

Motivation

- **Two main Use cases**
- Real-time Controller performance testing
- Algorithm and Interface development



RTC Performance testing

- Must verify that RTC prototype(s) can meet key performance requirements
 - Frame Rate
 - Latency
 - Jitter
- Ensure results valid when running at on-sky rates



Algorithm and Interface development

- Ensure that the algorithms implemented in the RTC give the expected results
- Develop and test interfaces between components
- Develop and test human interfaces to RTC



REQUIREMENTS

MTR - 1-Feb-2017



Laboratoire d'Études Spatiales et d'Instrumentation en Astrophysique





Requirements Summary

- Adaptive Optics Requirements
 - Simulate E-ELT scale AO system
- Multiple Wavefront Sensors
 - Laser and Natural Guide Stars
- Shack-Hartmann and Pyramid WFS Types
- Received feedback to simulated DM(s) to provide AO performance estimate



Requirements Summary

- Computational Requirements
 - Provide raw WFS pixel data
 - Frame rate up to 800Hz
 - Less than 1 μ s jitter
 - Provide 10 minutes of continuous data at full speed
 - Measure latency accurately by timing DM command time of arrival

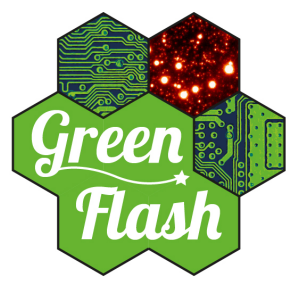

Requirements Summary

- Interface Requirements
 - Transport data over 10G Ethernet
 - Data should as closely as possible appear to originate from a real camera
 - Simulator should receive DM commands as feedback from GreenFlash telemetry



CONCEPT

MTR - 1-Feb-2017



Laboratoire d'Études Spatiales et d'Instrumentation en Astrophysique

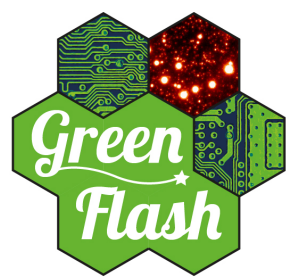

The logo for 'Green Flash' is a green hexagon with a white outline. Inside the hexagon, there are three smaller shapes: a green circuit board pattern, a red starburst pattern, and a green circuit board pattern. The words 'Green' and 'Flash' are written in white, stylized font across the hexagon.

Concept

- Unable to meet all requirements with single solution
 - End-to-end simulations cannot reach on-sky rates with no jitter
 - Deterministic hardware solutions cannot provide realistic data
- **Instead, a combined approach is pursued**



- End to end simulation to perform experiments with feedback to simulated DM
- Hardware based (FPGA) solution to send data deterministically at high frame rates
- End to end simulation used to record large data sets to be sent by FPGA



End to End simulation

- COMPASS Simulation used
 - ELT capable
 - Fast
 - Shack-Hartmann and Pyramid WFSs
- Data piped directly from GPU memory via FPGA to 10G Ethernet
 - Encapsulated with GigeVision Streaming Protocol
- (More in subsequent presentation)



Real-Time Data Shaper

- Recorded data sent at real-time rates from simulator server to RTC
- FPGA solution intercepts 10G Ethernet packets and provides deterministic timing
- Flexible solution allowing for any data type to be provided for RTC testing

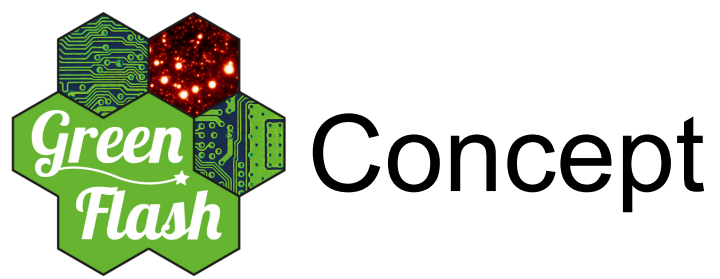

- **Two primary modes of operation:**
 - Simulation Rate Mode
 - On-sky Rate mode



Simulation Rate Mode

1. Data Generated by COMPASS
2. Data sent directly from GPU to FPGA
3. Data encapsulated as GVSP
4. Data sent to RTCS
5. DM commands received by COMPASS, providing feedback to simulation

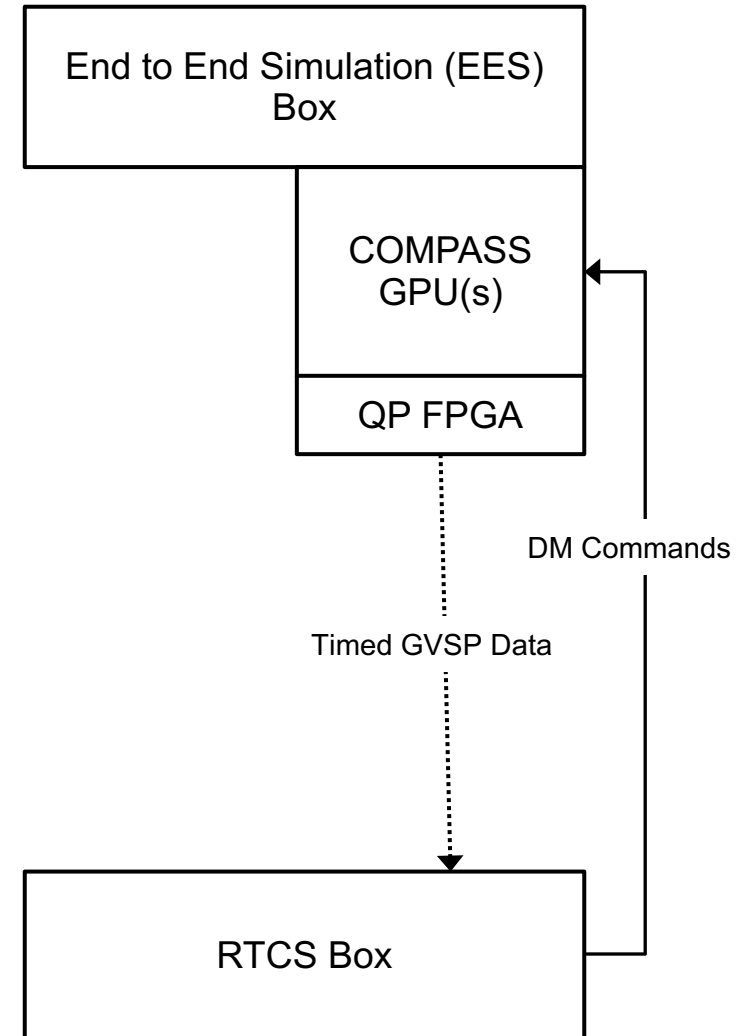



Simulation Rate Mode

- COMPASS operates as fast as possible (~100s Hz at ELT scale)
 - Future goal is on-sky rate
- Data extracted from GPU by FPGA to avoid simulation slow down
- Can operate in closed loop and assess AO performance
- Can quickly change AO parameters

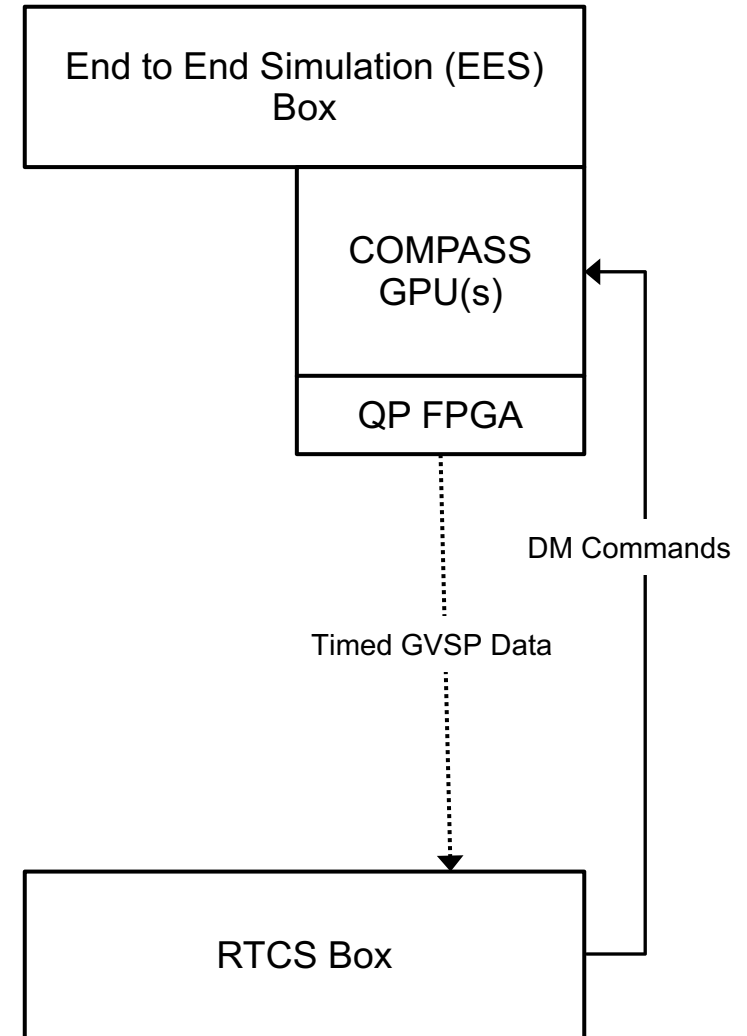



On-sky Rate Mode

1. Large WFS data set generated by COMPASS, encapsulated as GVSP and stored
2. Data sent to 10G Ethernet at on-sky frame rate
3. Data packets intercepted by RTDS, and buffered
4. Data sent out with deterministic timing to RTCS box
5. DM Commands received and saved in data store for later analysis

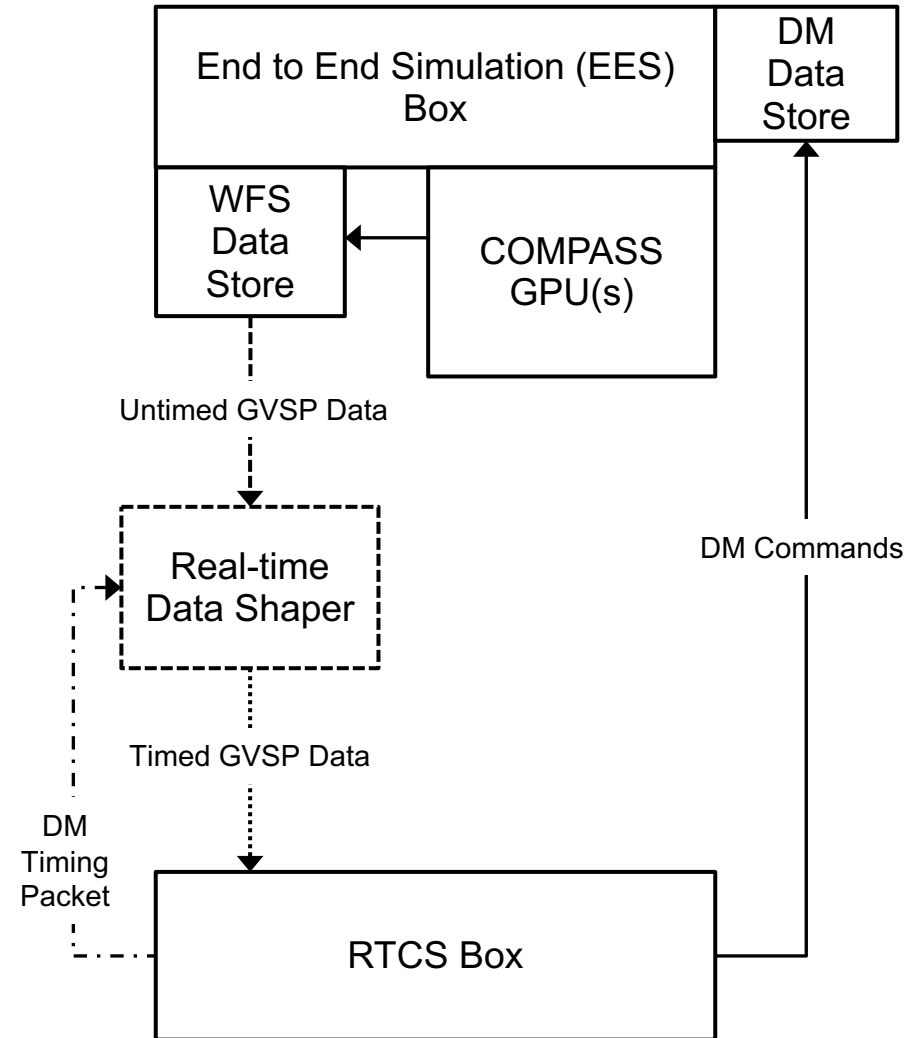



On-sky Rate Mode

- Can operate at on-sky rate and measure latency accuracy
- Minimal jitter from RTDS
- Realistic data provided
 - but no AO feedback
- Data stored to ensure reconstruction successful
- Flexible design allows data from any source to be used

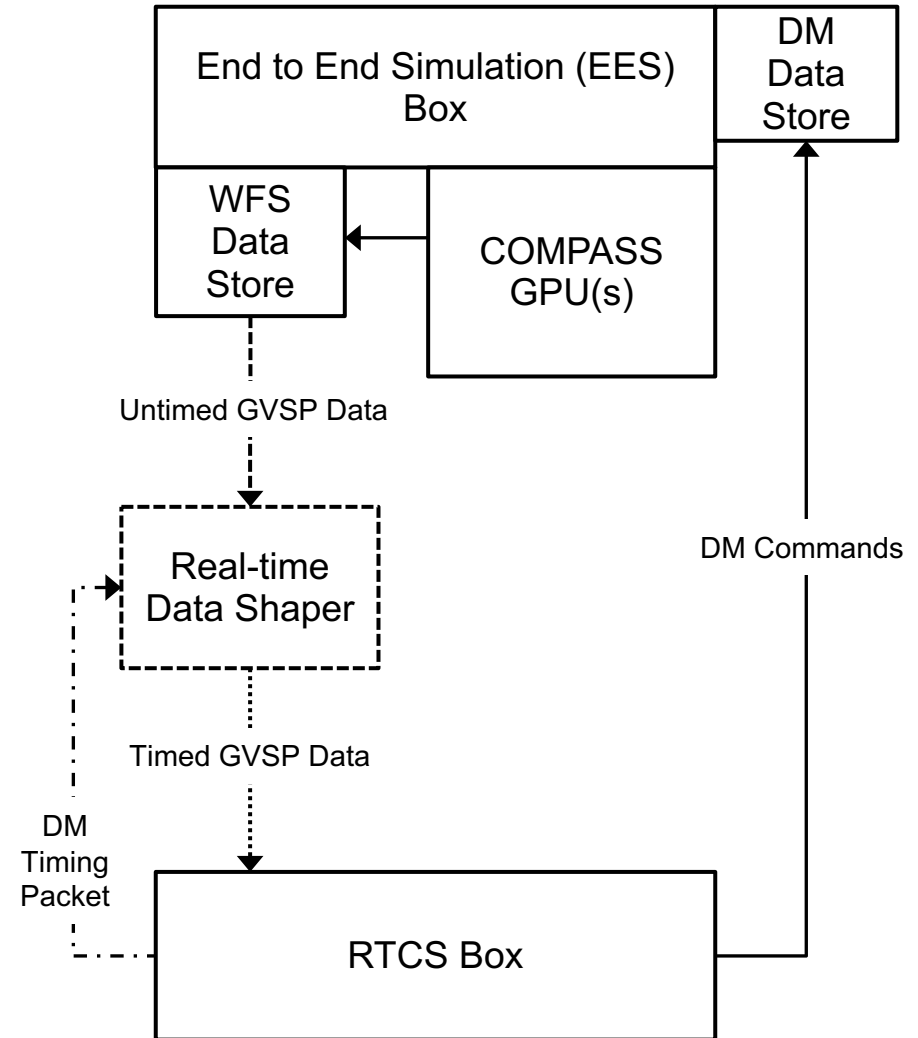



Real-time Data Shaper

- FPGA Board with multiple 10G Ethernet ports
- Transparent to sender and receiver
 - Clones sender IP and MAC address
- Intercepts and buffers packets from specified UDP port
- Resends that data with accurate timing
- Drop into existing 10G link to add timing



Timeline

- Now:
 - Currently have SCAO implementation of COMPASS + QP FPGA
- April 2017
 - Prototype Data Store, sending data as GVSP through 10G Ethernet
 - Prototype Real-time Data Shaper FPGA board
- October 2017
 - Full SCAO simulator prototype, able to send data deterministically as GVSP at either "Simulation Rate" or "On-sky Rate"
- January 2018
 - Full MAORY scale multi-WFS simulator



Summary

- GreenFlash simulator will be used to assess RTC prototype performance and develop interfaces and algorithms
- It has exacting requirements to ensure it can run with low latency at on-sky rates whilst supplying realistic AO WFS data
- A solution using the End to End simulation COMPASS and a FPGA based timing boards is envisaged and is under development



COMPASS

WP 6.3: Simulation software

GreenFlash Mid-Term Review

MTR - 1-Feb-2017



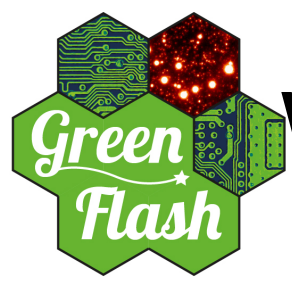

What is COMPASS?

- COMPUting Platform for Adaptive opticS System
- End-to-end AO simulation platform
- GPU acceleration
- ELT scale

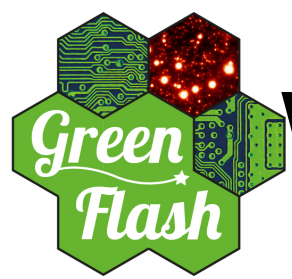

What is COMPASS?

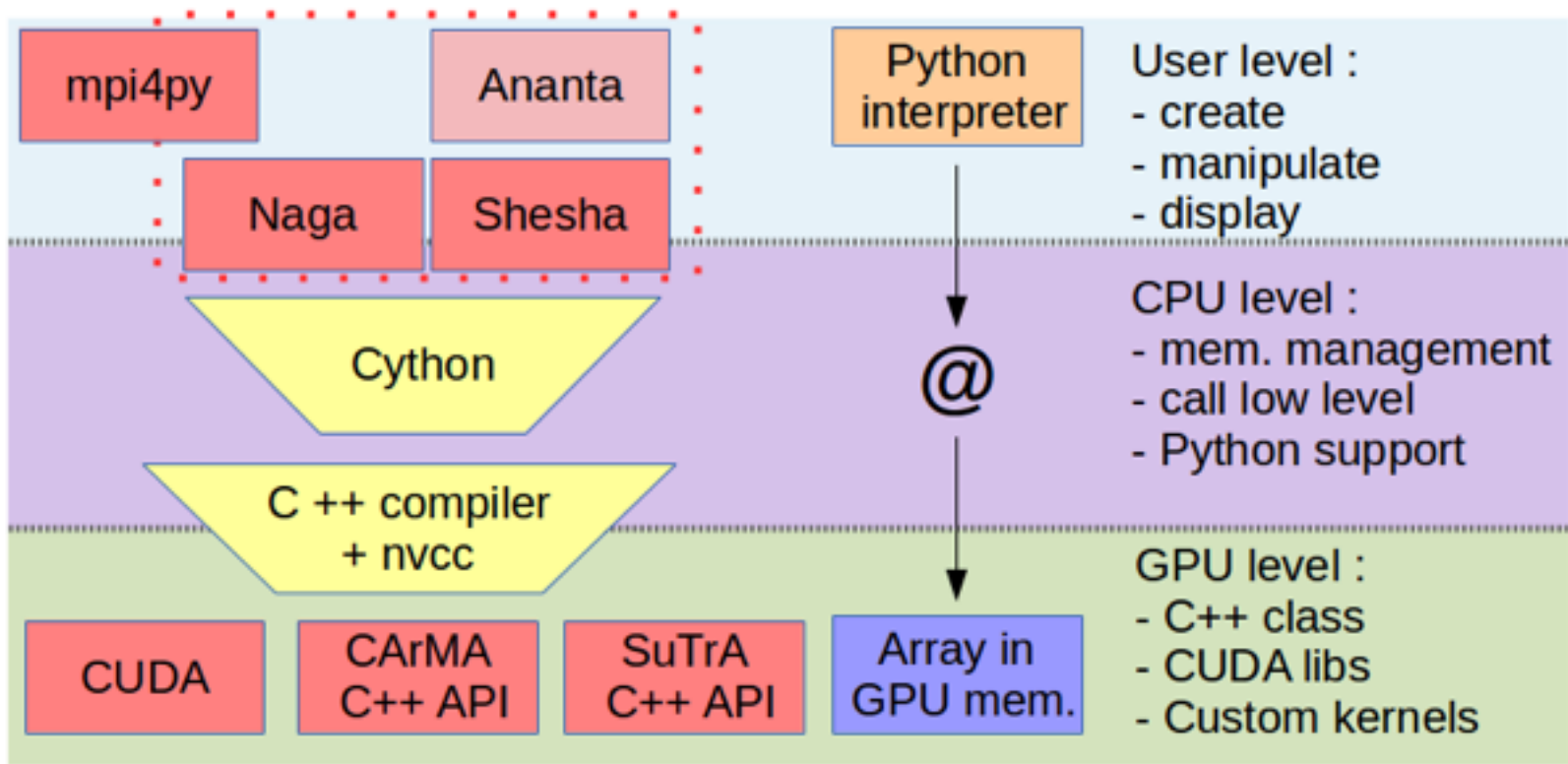

User interface coded in Python for long term maintenance

Main computations relies on GPU:

- **CArMA**: C++ Api for Massively parallel Applications
- **SuTrA**: Simulation Tool for Adaptive optics
- Use optimized libraries such as CUBLAS, CUFFT, MAGMA...

Wavefront Sensor models:

- Shack-Hartmann
- Pyramid
- Laser Guide Star

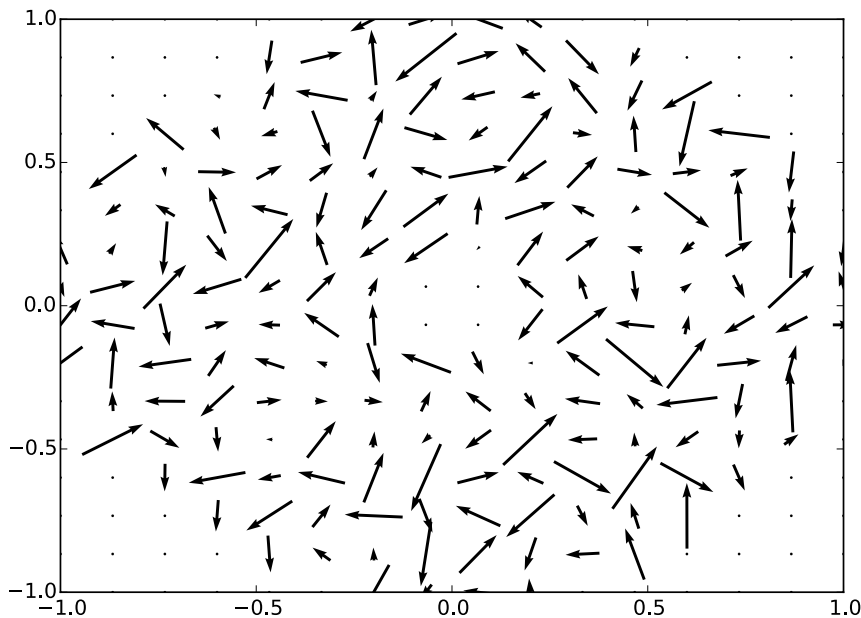
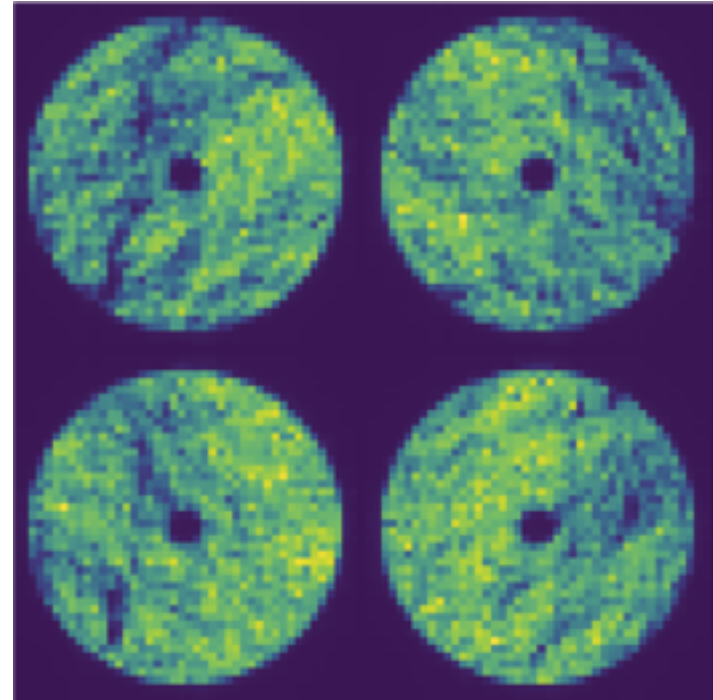

Centroiding methods:

- Center of gravity (cog)
- Thresholded cog
- Weighted cog
- Brightest pixels
- Correlation



Features

Controllers:

- Least square
- Modal optimization
- Minimum variance
- CuReD
- Projection

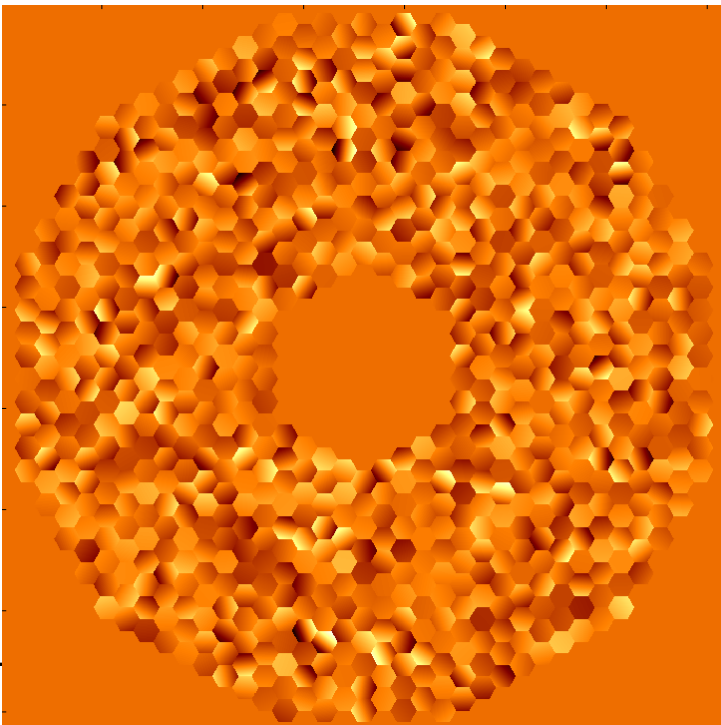

E-ELT:

- Hexagonal pupil
- Spiders
- Phase aberration
- M4 influence functions



Simulation process

User parameters file

Initializations

WFS

Atmosphere

Target

DMs

RTC

AO Loop

move atmos

phase on
WFS

WFS image

Centroids

Commands

DM shape

CPU

CPU + GPU allocations

GPU



Performance

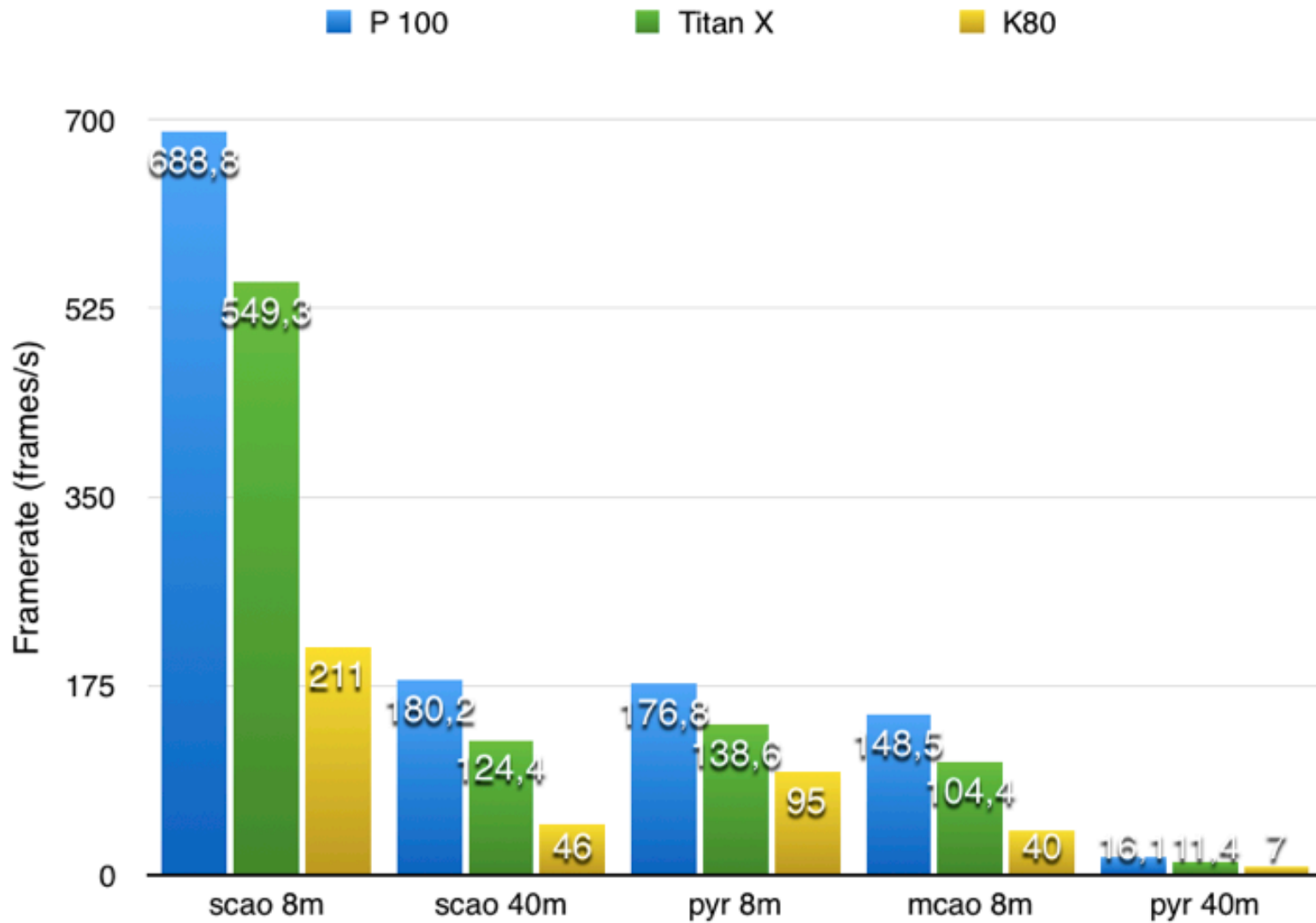



Performance

